

**Aldeck**

*Revised July 2022*

# **Aldeck**

---

# **GROUP**

**Roofing  
Handrail  
Systems**

15 Brock Street, Thomastown VIC 3074  
Tel: (03) 9465 1122 Fax: (03) 9465 1126  
Email: [aldeck@aldeck.com.au](mailto:aldeck@aldeck.com.au) [www.aldeck.com.au](http://www.aldeck.com.au)

<b>CONTENTS</b>	<b>PAGE</b>
<b>Over Purlin Systems</b>	
Perimeter Handrail	1
Purlin Handrail (Gable End)	2
<b>Under Purlin Systems</b>	
Purlin Handrail (Under Slung)	3
Gable End Application	4
Horizontal Bolt On Handrail	5
<b>Over Purlin Systems</b>	
665 Handrail System	6
Clamp on Bracket	7
Bolt on Bracket	8
<b>Under Purlin Systems</b>	
J Bar / PFC Handrail	9
J Bar / PFC Handrail (Alternate)	10
I Beam Handrail	11
Purlin Handrail (Under Slung Offset)	12
Timber Beam Handrail (Offset)	13
Timber Beam Handrail	14
Blue Steel Bracket	15
<b>665 System</b>	
Stair Case Connector	16
<b>Roof Mounted Systems</b>	
Roof Mounted Clamp On	17
Roof Mounted Screw Down	18
Roof Mounted	19

## Perimeter Handrail

Aldeck

OVER PURLIN

- Maximum post spacing is **3 metres**.
- All rails, joiners & corner brackets included.
- When installing or dismantling, this work must be in accordance with state legislation under the OH&S act.

Join rails at post

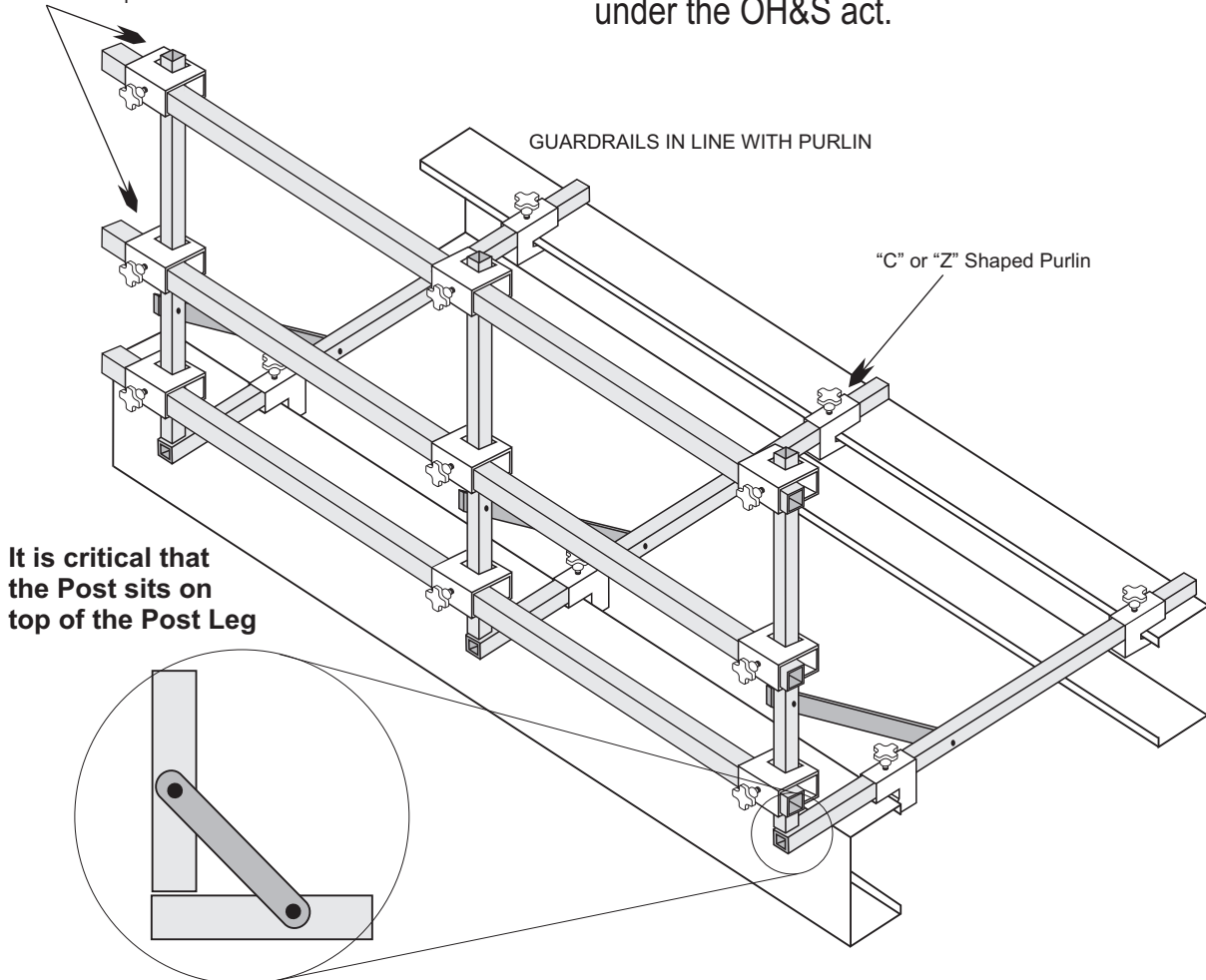

It is critical that the Post sits on top of the Post Leg

*Our unique system allows the roof and the walls to be installed at the same time, greatly increasing site productivity.*

*The productivity gains are further improved by not having to change from perimeter systems to roof systems during a project.*

## Gable End Application

Aldeck

OVER PURLIN

- Maximum post spacing is **3 metres**.
- All rails, joiners & corner brackets included.
- When installing or dismantling, this work must be in accordance with state legislation under the OH&S act.

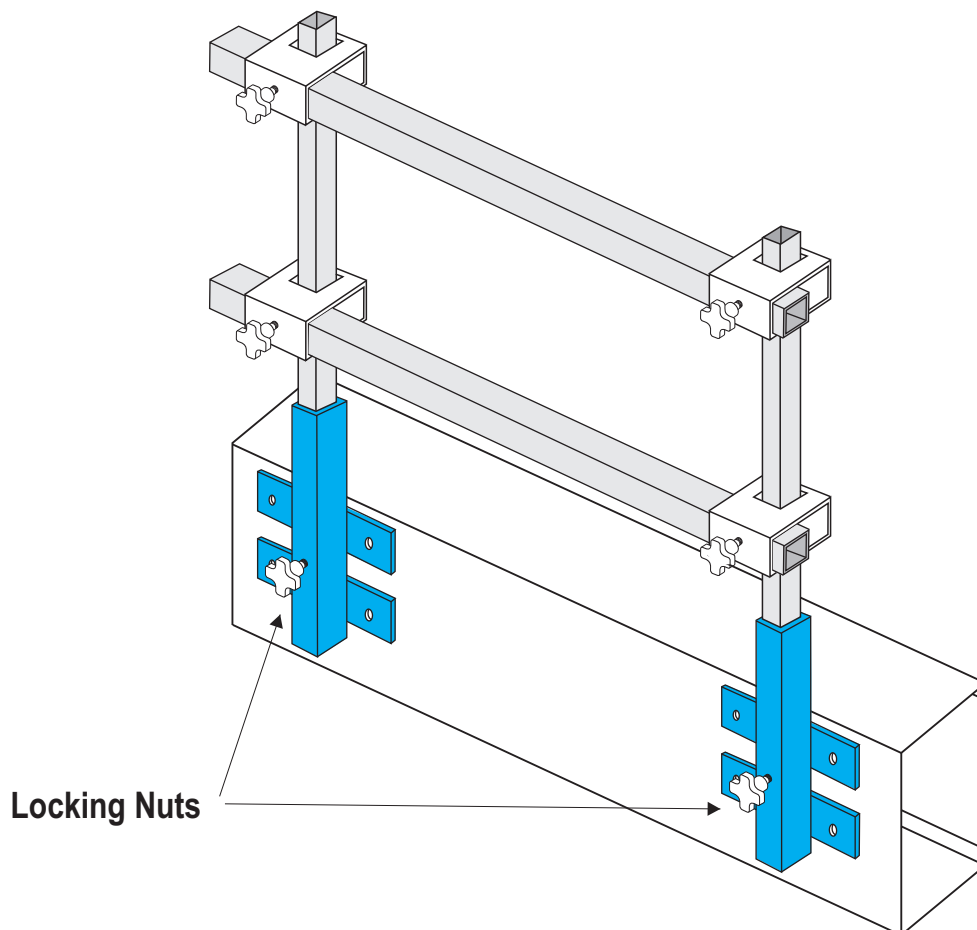

*Our unique system allows the roof and the walls to be installed at the same time, greatly increasing site productivity.*

*The productivity gains are further improved by not having to change from perimeter systems to roof mounted systems during a project.*

## Purlin Handrail (Under Slung)

Aldeck

UNDER PURLIN

- Maximum post spacing is **3 metres**.
- All rails, joiners & corner brackets included.
- When installing or dismantling, this work must be in accordance with state legislation under the OH&S act.

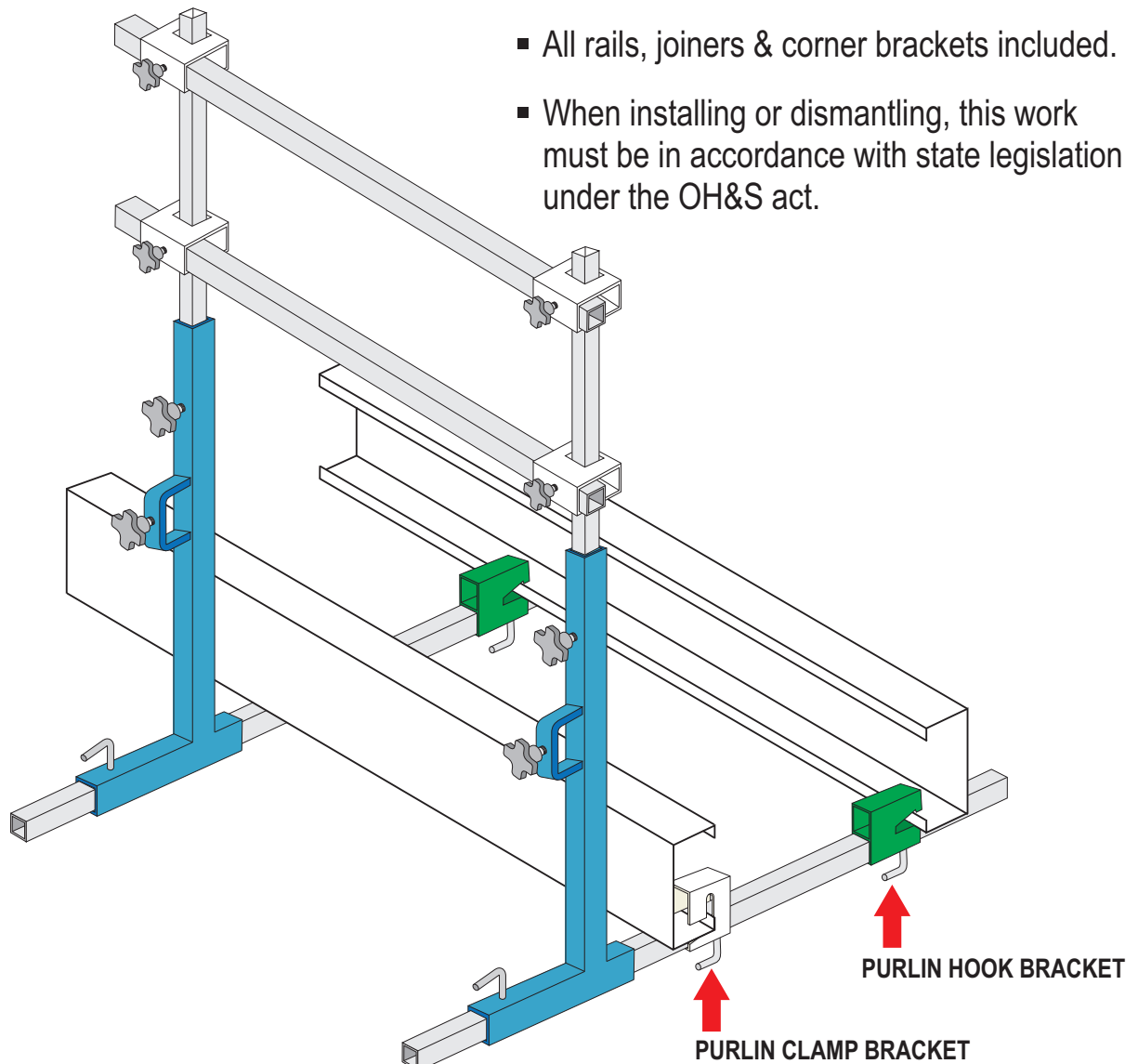

*The Aldeck Alternate Perimeter System*

*Lighter weight with less components than similar competitors products, improving site productivity.*

## Purlin Handrail (Gable End)

Aldeck

UNDER PURLIN

- Maximum post spacing is **3 metres**.
- All rails, joiners & corner brackets included.
- When installing or dismantling, this work must be in accordance with state legislation under the OH&S act.

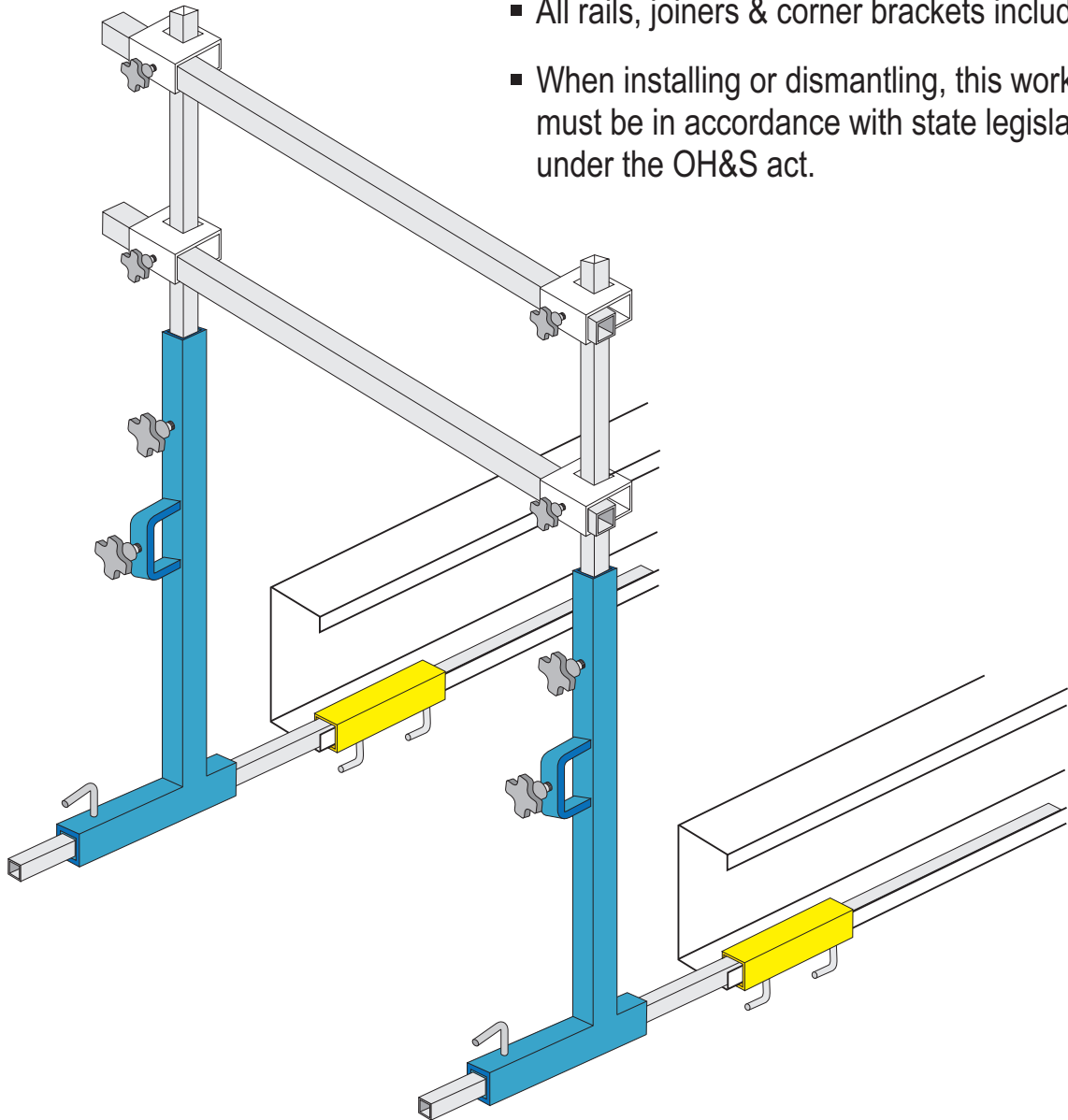

*The Aldeck Alternate Perimeter System*

*Lighter weight with less components than similar competitors products, improving site productivity.*

## Horizontal Bolt On Handrail

Aldeck

UNDER PURLIN

- Maximum post spacing is **3 metres**.
- All rails, joiners & corner brackets included.
- When installing or dismantling, this work must be in accordance with state legislation under the OH&S act.

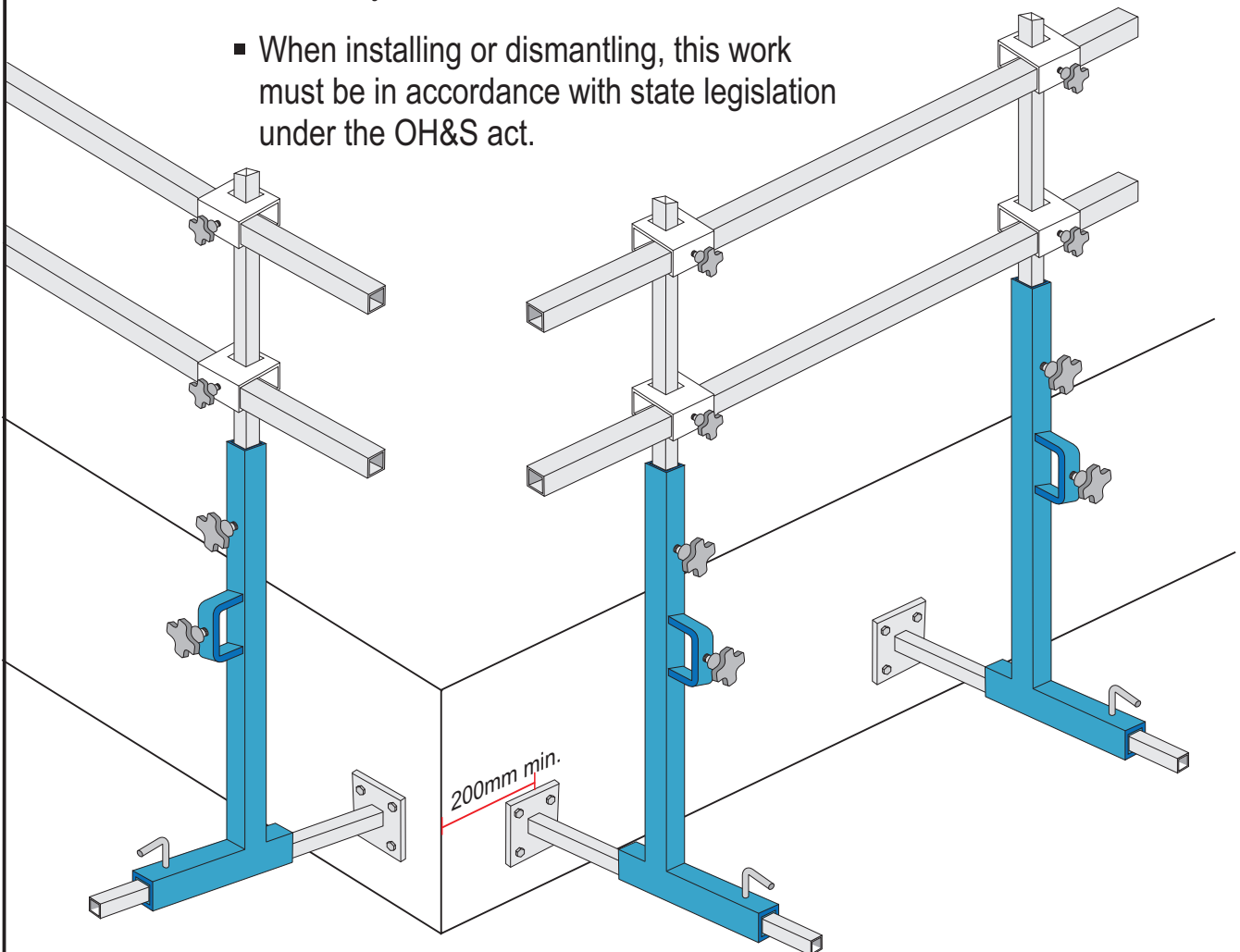

*The Aldeck Bolt On System can be attached to many different structure types.*

*This system is lighter weight with less components than similar competitors products, improving site productivity.*

## 665 Telescopic Handrail System

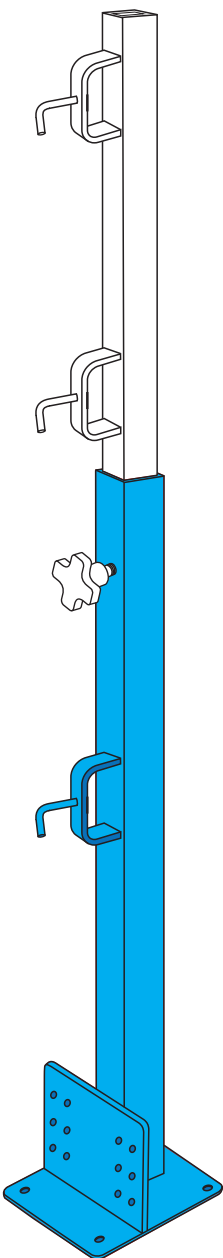
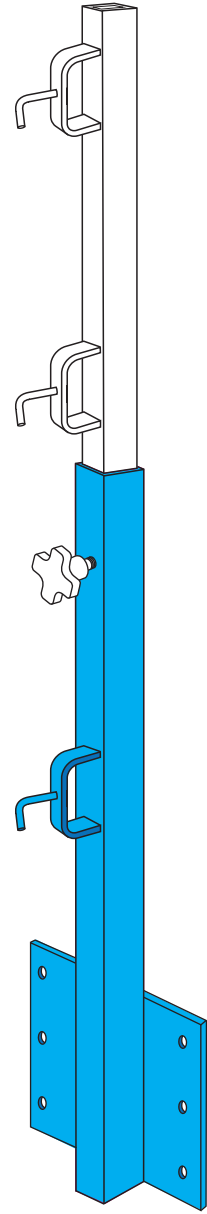
<b>BOLT DOWN BRACKET</b>	<b>SIDE MOUNT BRACKET</b>
	
<p><i>The mid range system from Aldeck</i></p> <ul style="list-style-type: none"><li>• <i>Has the capacity to extend up to 1.6 m high</i></li><li>• <i>Maximum spacing between posts is 3m</i></li><li>• <i>The perfect balance between strength and weight</i></li></ul>	



## Clamp on Bracket

Aldeck

OVER PURLIN

- Maximum post spacing is **3 metres**.
- All rails, joiners & corner brackets included.
- When installing or dismantling, this work must be in accordance with state legislation under the OH&S act.

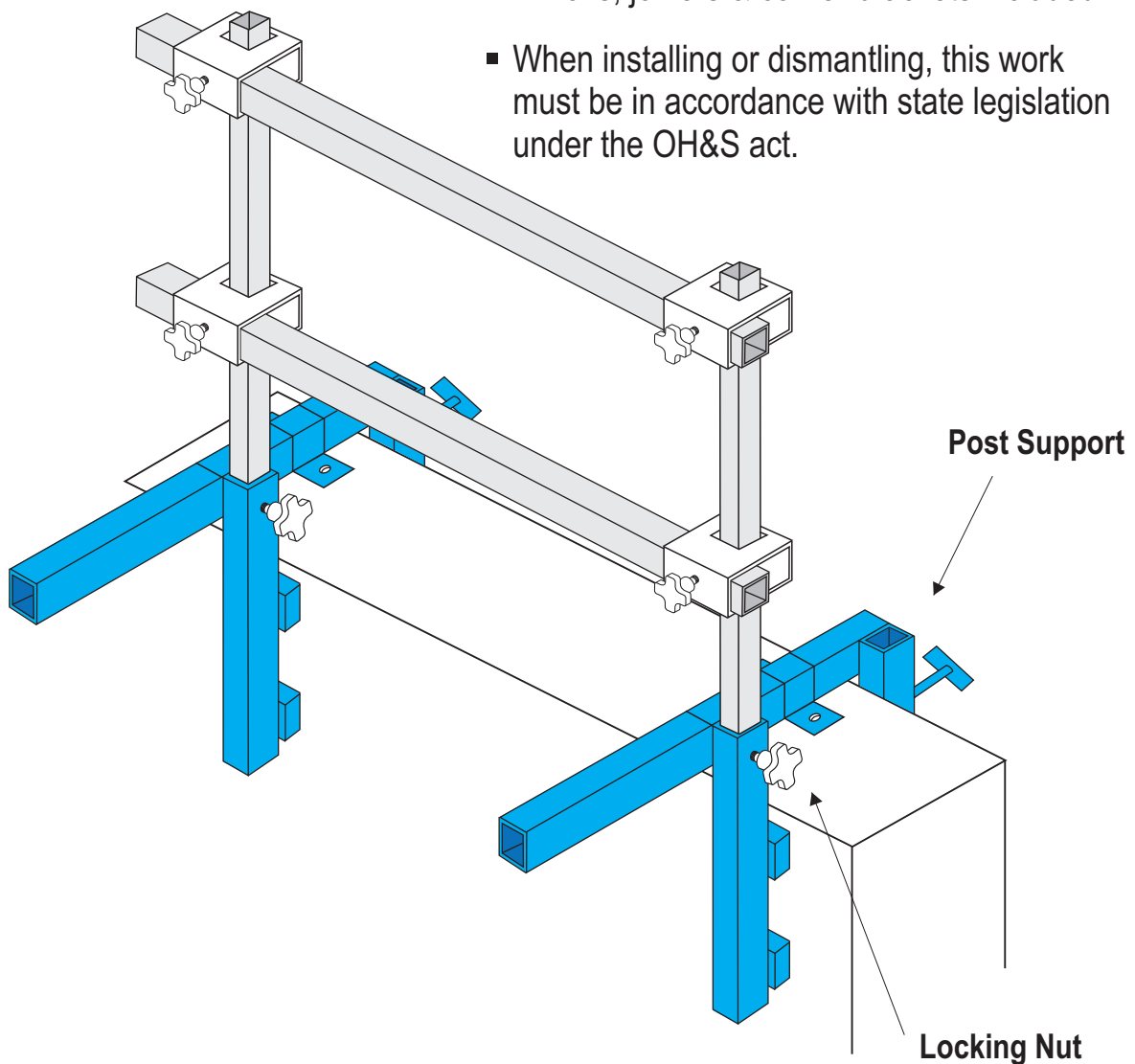

*Our new and improved clamp on bracket, firmly connects to panel walls or hobs.*

*Up to 400mm wide, all without the need of mechanical fixings being required.*

## Bolt on Bracket

Aldeck

OVER PURLIN

- Maximum post spacing is **3 metres**.
- All rails, joiners & corner brackets included.
- When installing or dismantling, this work must be in accordance with state legislation under the OH&S act.

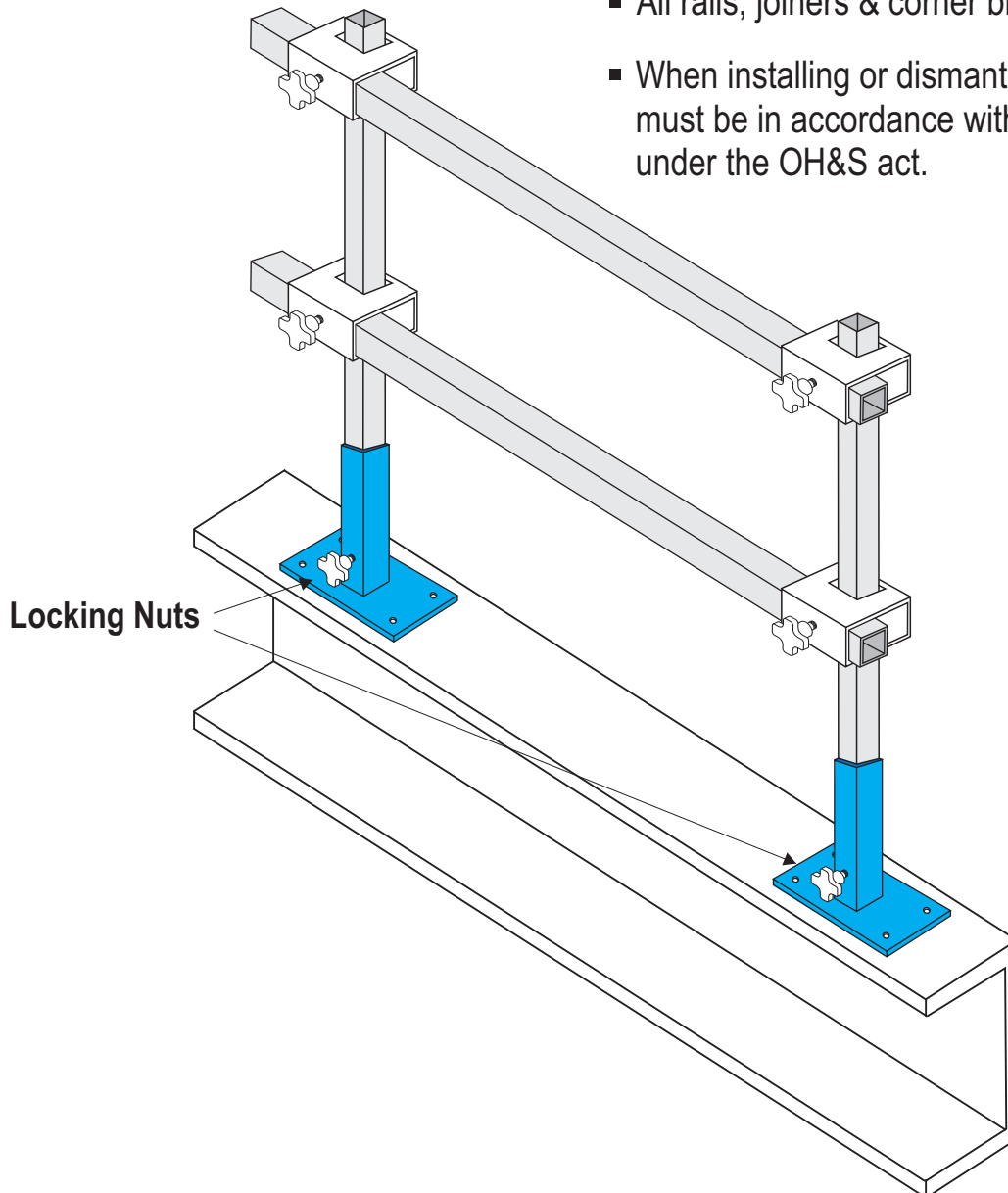

*Our Roofers Handrail System - quickly and easily attaches to steel beams, timber structures or concrete surfaces with the use of 12 gauge screws.*

## J Bar / PFC Handrail

Aldeck

UNDER PURLIN

- Maximum post spacing is **3 metres**.
- All rails, joiners & corner brackets included.
- When installing or dismantling, this work must be in accordance with state legislation under the OH&S act.

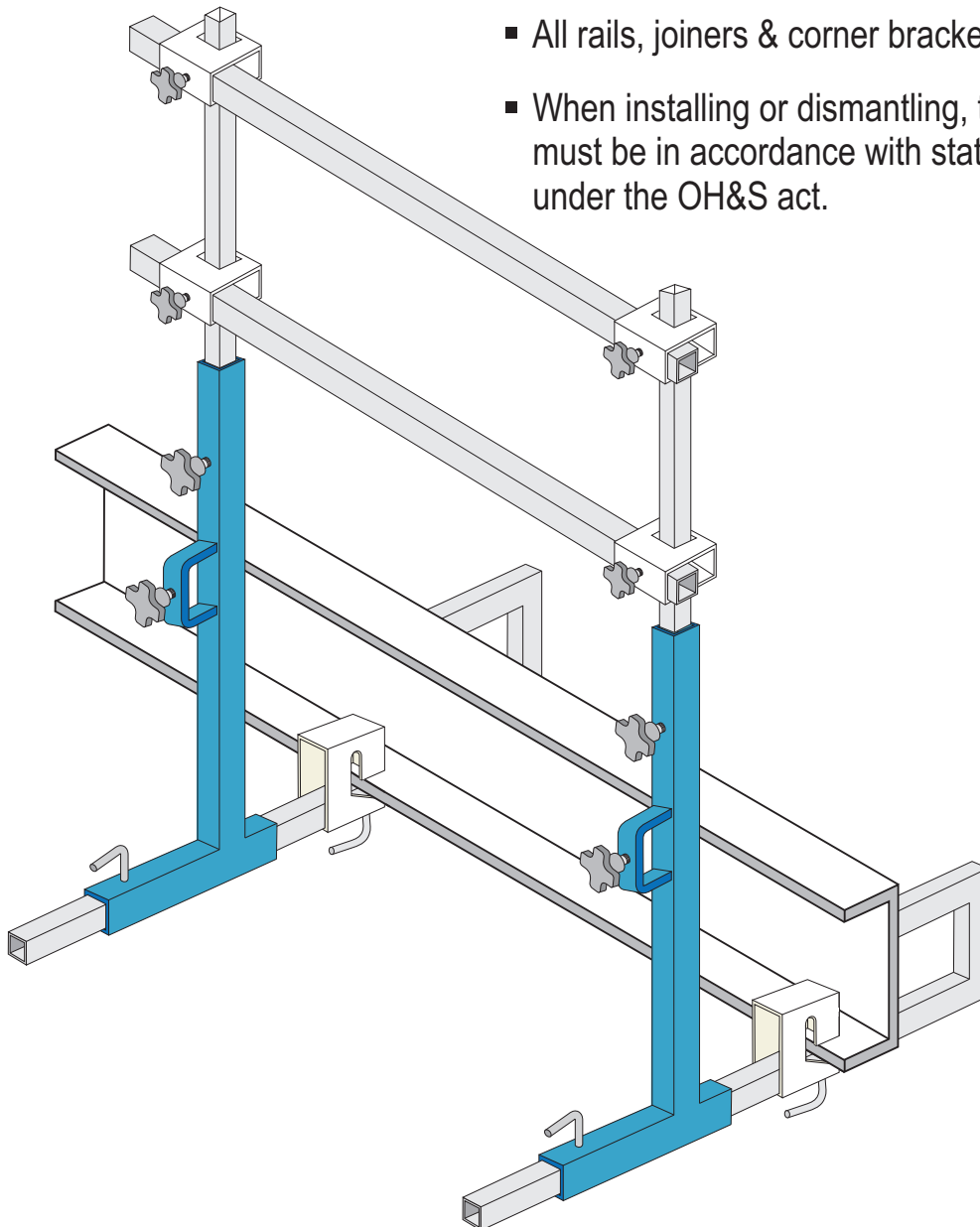

*The Aldeck Alternate Beam Connecting System*

*Lighter weight with less components than similar competitors products, improving site productivity.*

## J Bar / PFC Handrail (Alternate)

Aldeck

UNDER PURLIN

- Maximum post spacing is **3 metres**.
- All rails, joiners & corner brackets included.
- When installing or dismantling, this work must be in accordance with state legislation under the OH&S act.

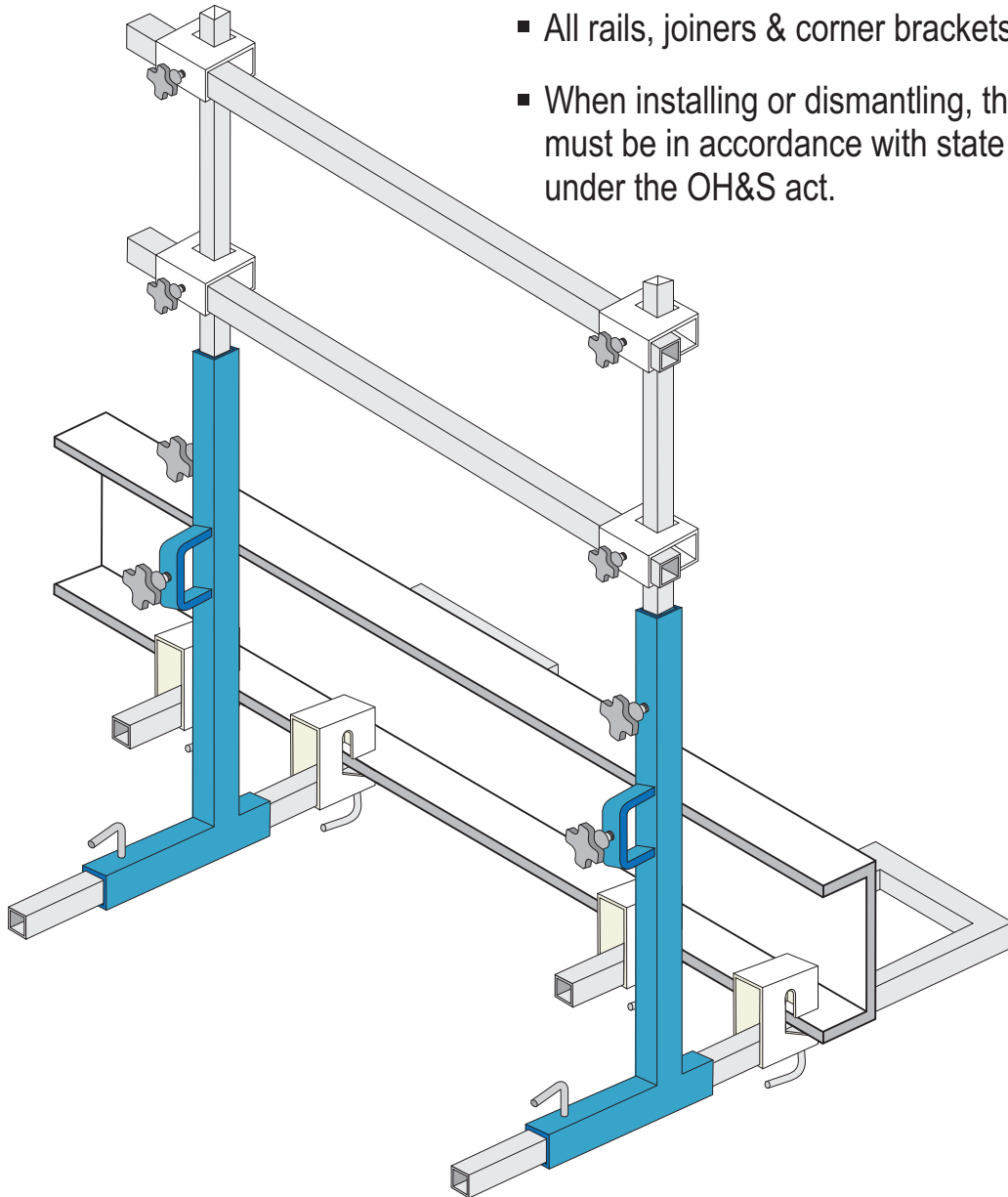

*The Aldeck Alternate Beam Connecting System*

*Lighter weight with less components than similar competitors products, improving site productivity.*

## I Beam Handrail

Aldeck

UNDER PURLIN

- Maximum post spacing is **3 metres**.
- All rails, joiners & corner brackets included.
- When installing or dismantling, this work must be in accordance with state legislation under the OH&S act.

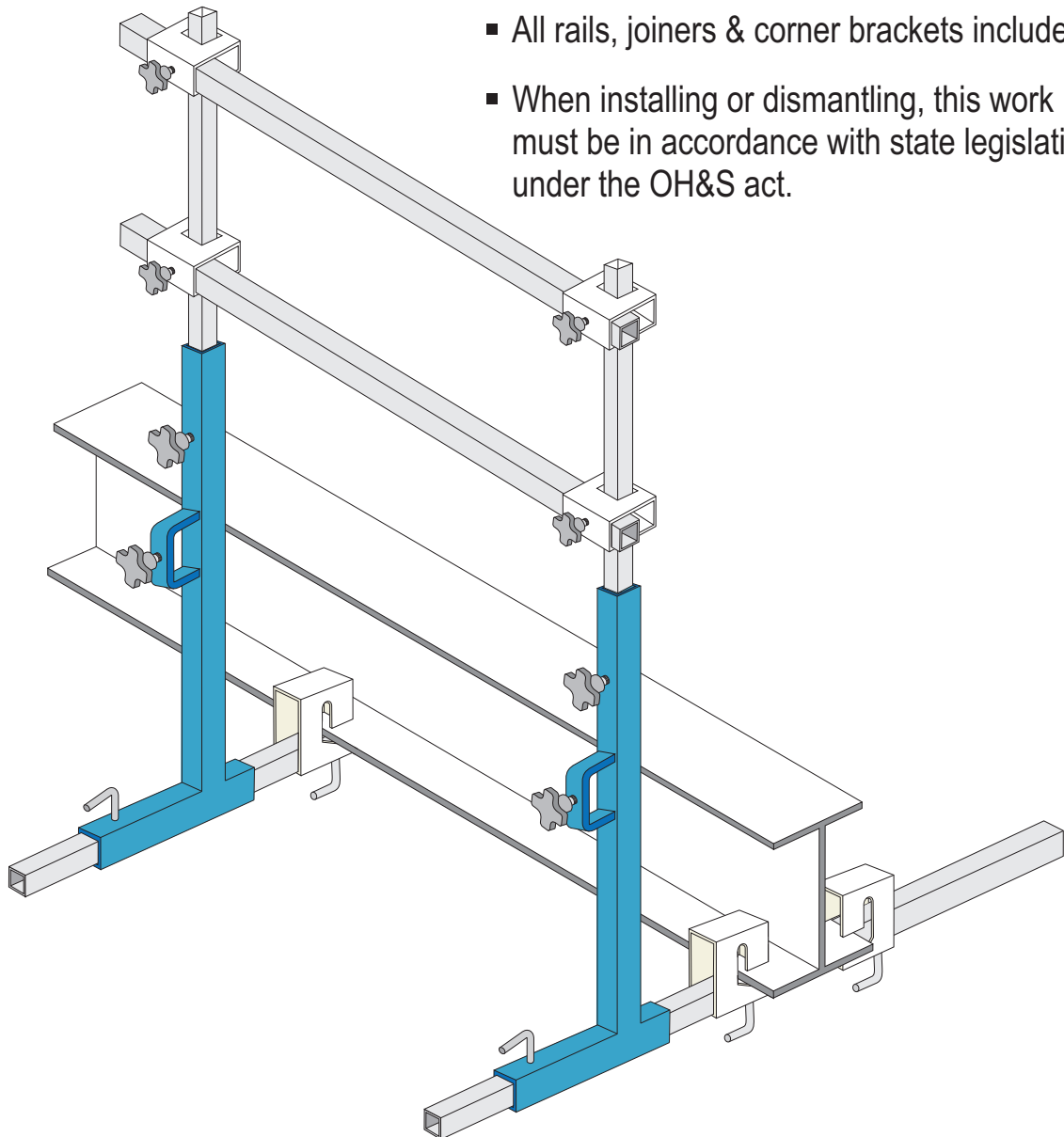

*The Aldeck Alternate I Beam System*

*Lighter weight with less components than similar competitors products, improving site productivity.*

## Purlin Handrail (Under Slung Offset)

Aldeck

UNDER PURLIN

- Maximum post spacing is **3 metres**.
- All rails, joiners & corner brackets included.
- When installing or dismantling, this work must be in accordance with state legislation under the OH&S act.

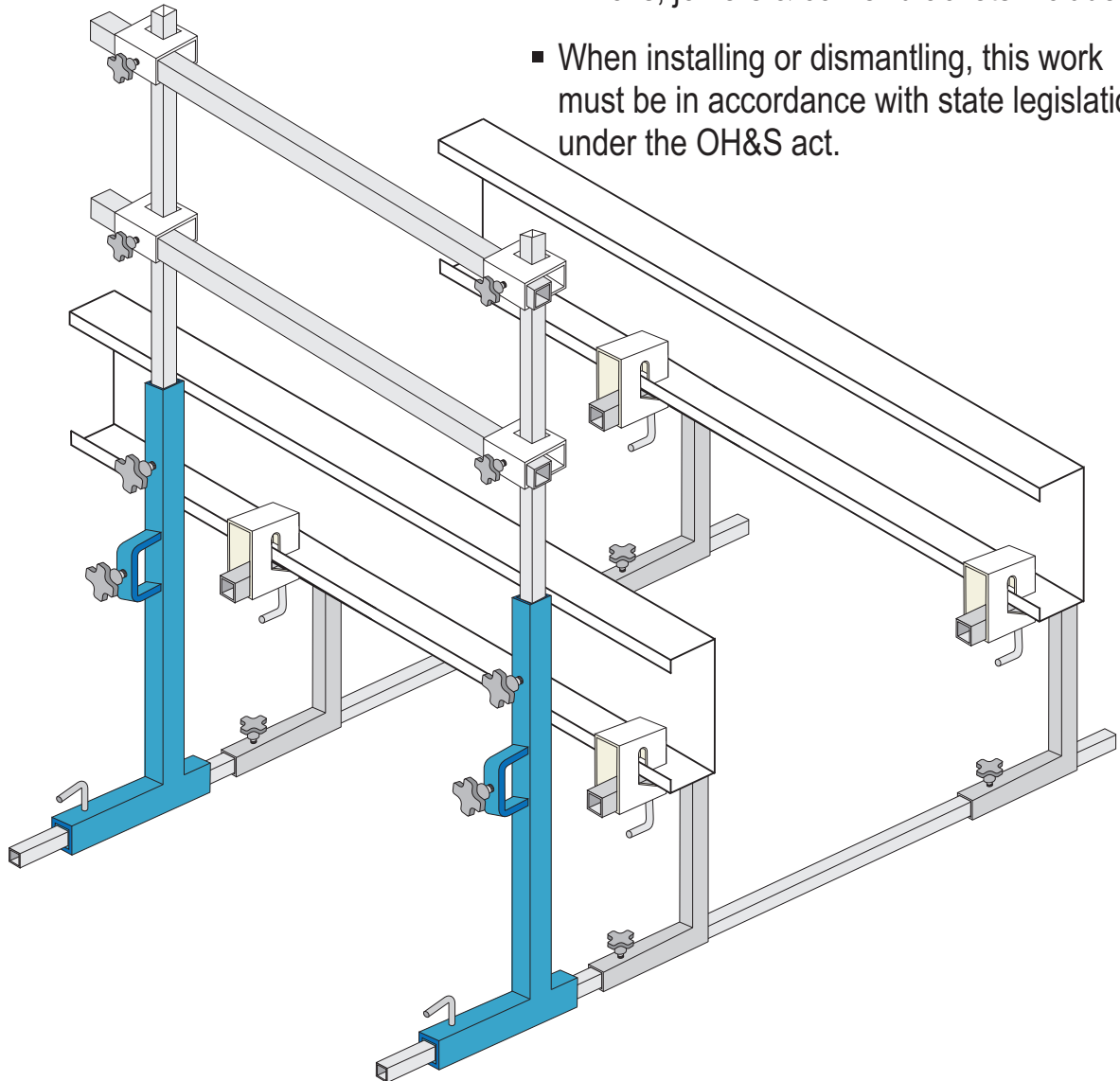

*The Aldeck Alternate Perimeter System*

*Lighter weight with less components than similar competitors products, improving site productivity.*

## Timber Beam Handrail (Offset)

Aldeck

UNDER PURLIN

- Maximum post spacing is **3 metres**.
- All rails, joiners & corner brackets included.
- When installing or dismantling, this work must be in accordance with state legislation under the OH&S act.

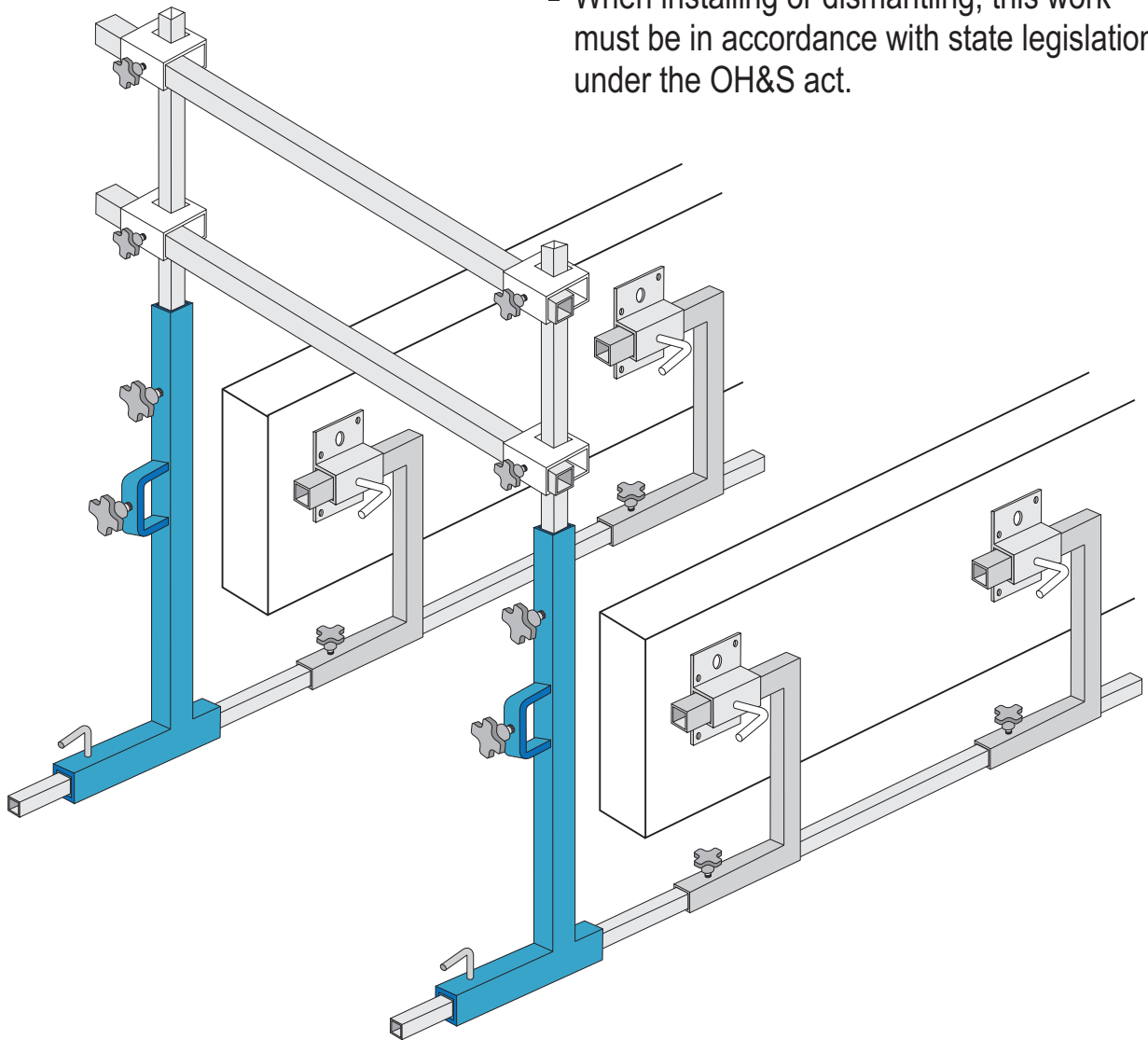

*The Aldeck Alternate Perimeter System*

*Lighter weight with less components than similar competitors products, improving site productivity.*

## Timber Beam Handrail

Aldeck

UNDER PURLIN

- Maximum post spacing is **3 metres**.
- All rails, joiners & corner brackets included.
- When installing or dismantling, this work must be in accordance with state legislation under the OH&S act.

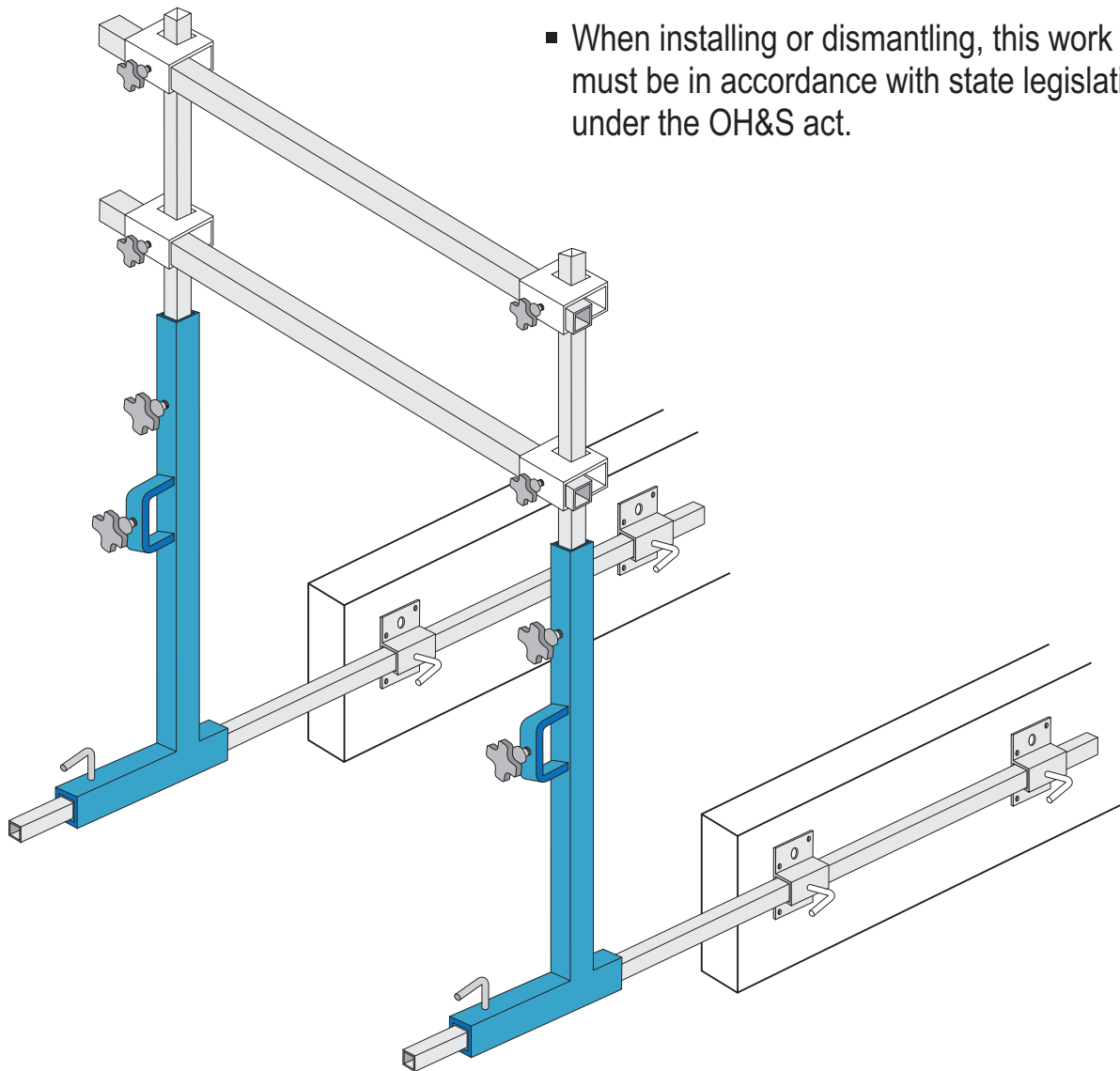

*The Aldeck Alternate Perimeter System with Timber Beam Connectors*

*Lighter weight with less components than similar competitors products, improving site productivity.*



## Blue Steel Bolt On Handrail

Aldeck

UNDER PURLIN

- Maximum post spacing is **3 metres**.
- All rails, joiners & corner brackets included.
- When installing or dismantling, this work must be in accordance with state legislation under the OH&S act.

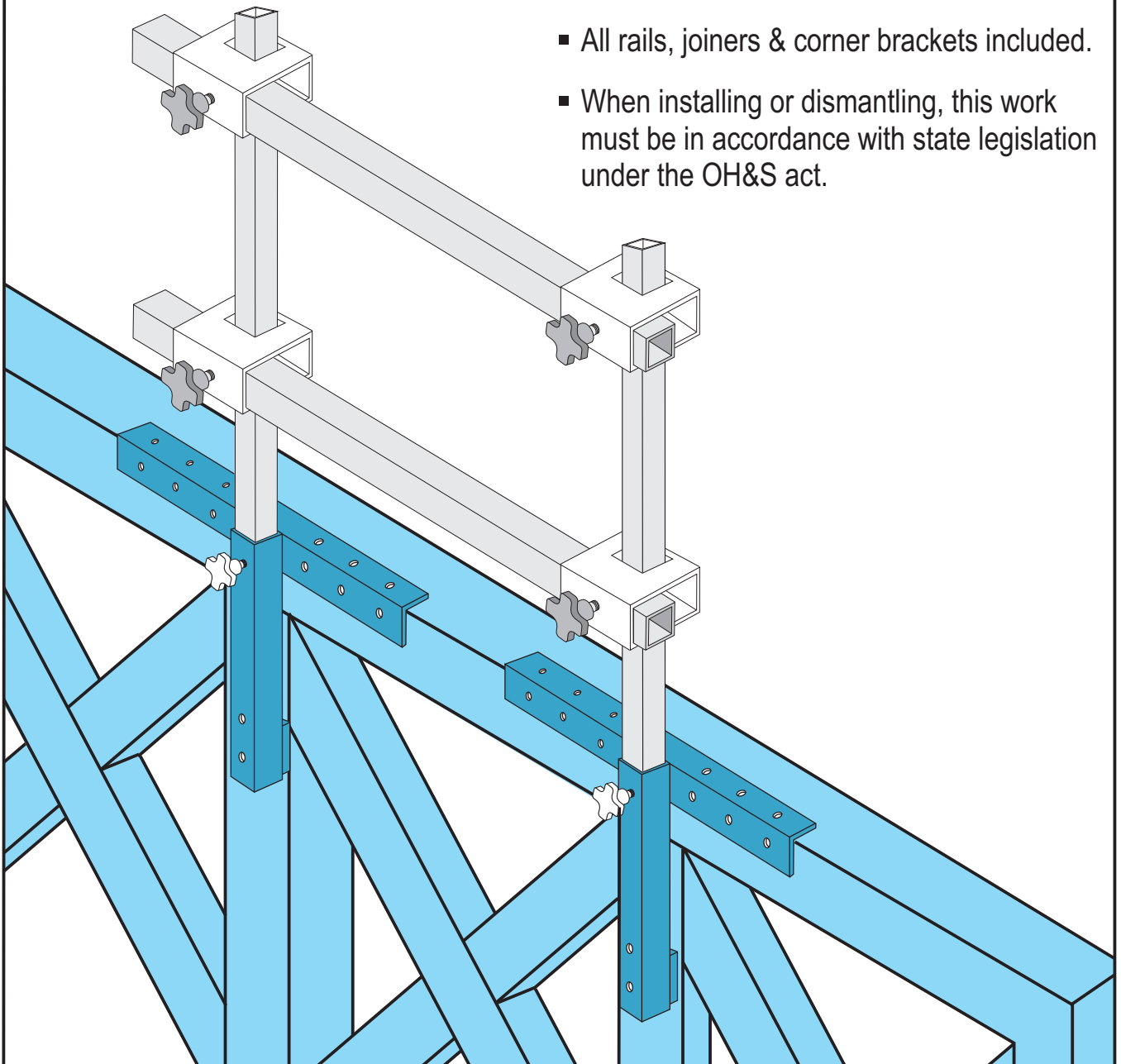

*Our answer to light weight blue steel structures.*

*With many buildings being constructed with thinner and lighter steel, a new multi fixed bracket is required for handrail systems to continue to comply with Australian Standards.*

## Telescopic Handrail System

Aldeck

STAIR CASE CONNECTOR

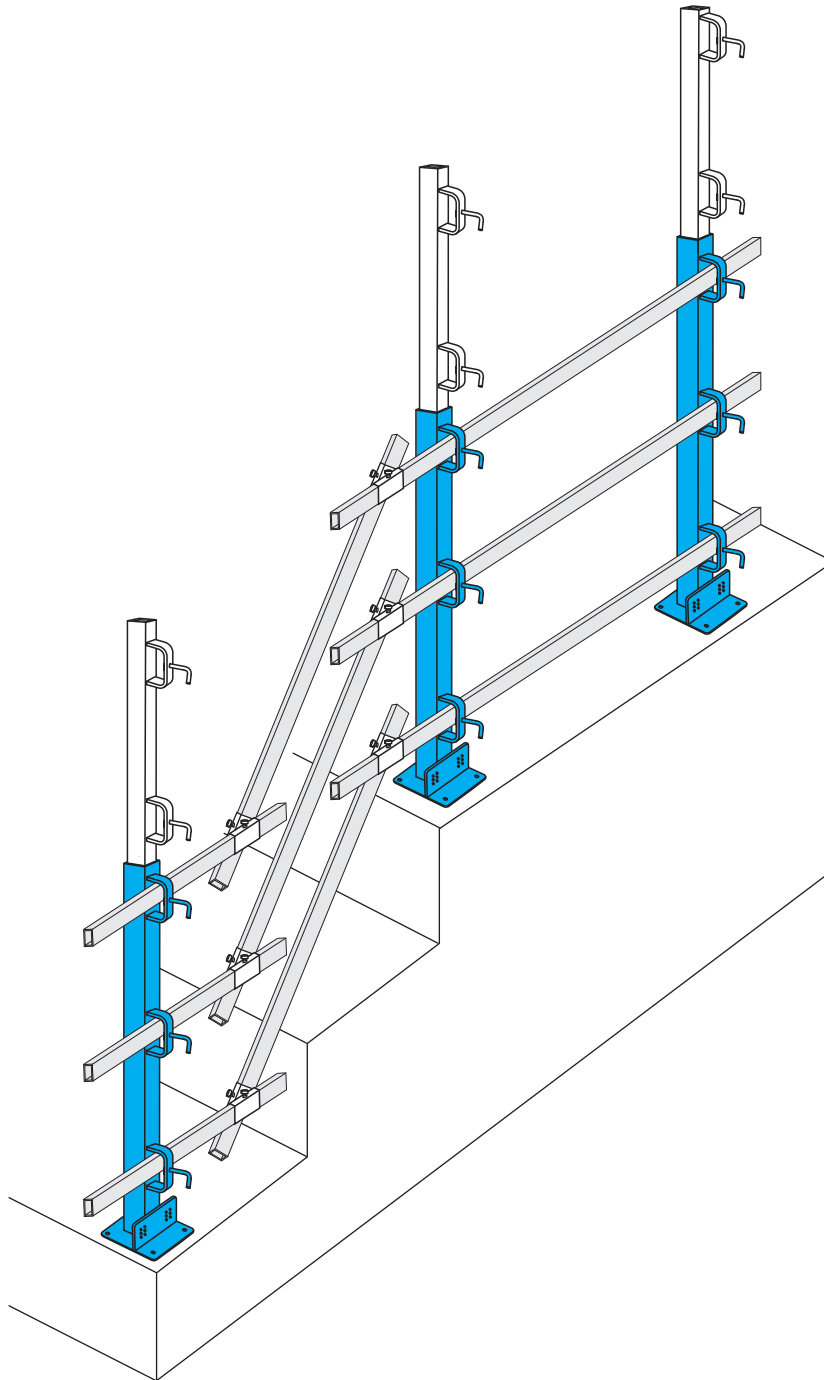

*Adds further flexibility to the handrail system  
by allowing it to now be used on staircases.*

## Roof Mounted Handrail System

Aldeck

Clamp On System

- Maximum post spacing is **3 metres**.
- All rails, joiners & corner brackets included.
- When installing or dismantling, this work must be in accordance with state legislation under the OH&S act.

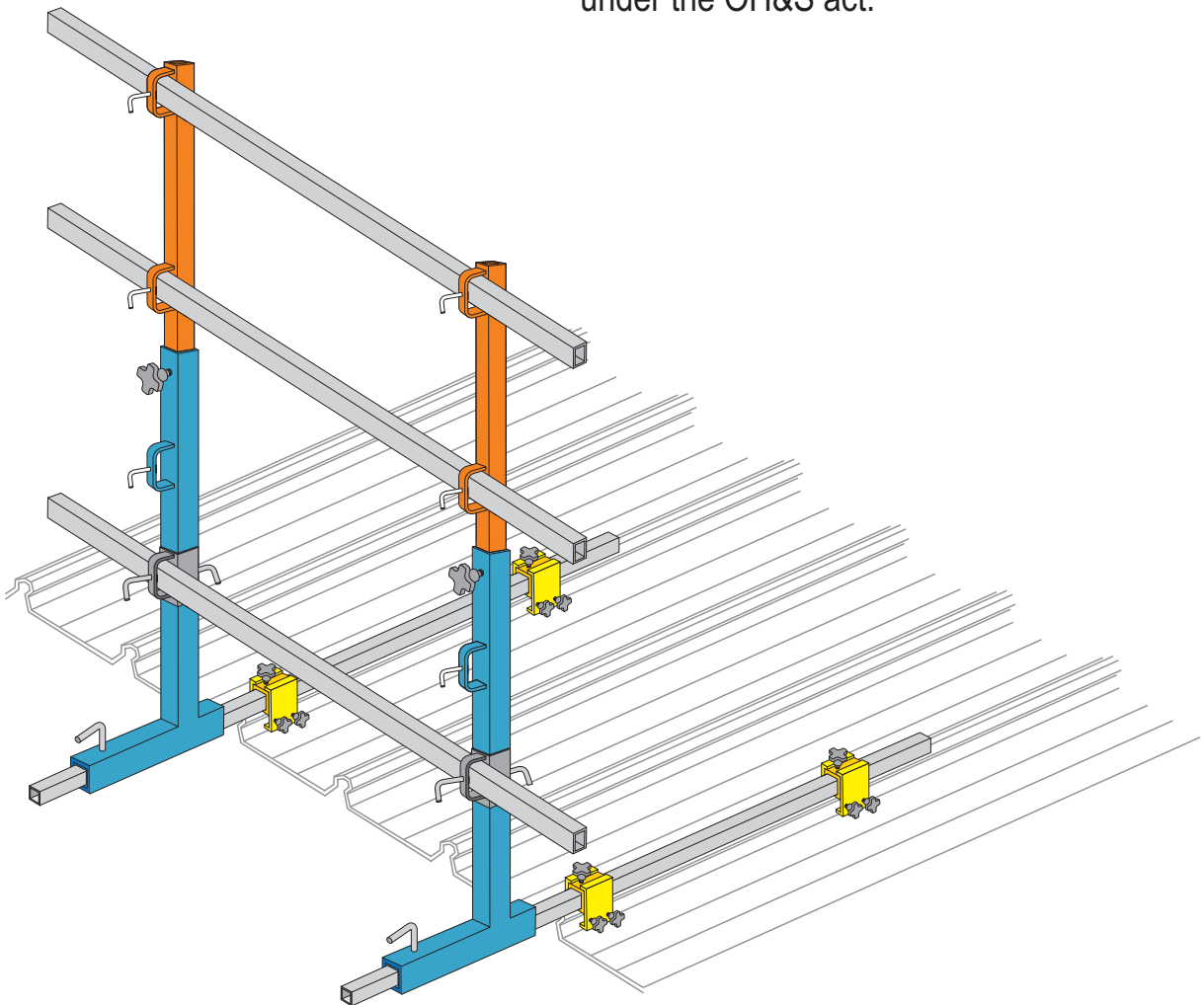

## Roof Mounted Handrail System

Aldeck

Screw Down System

- Maximum post spacing is **3 metres**.
- All rails, joiners & corner brackets included.
- When installing or dismantling, this work must be in accordance with state legislation under the OH&S act.

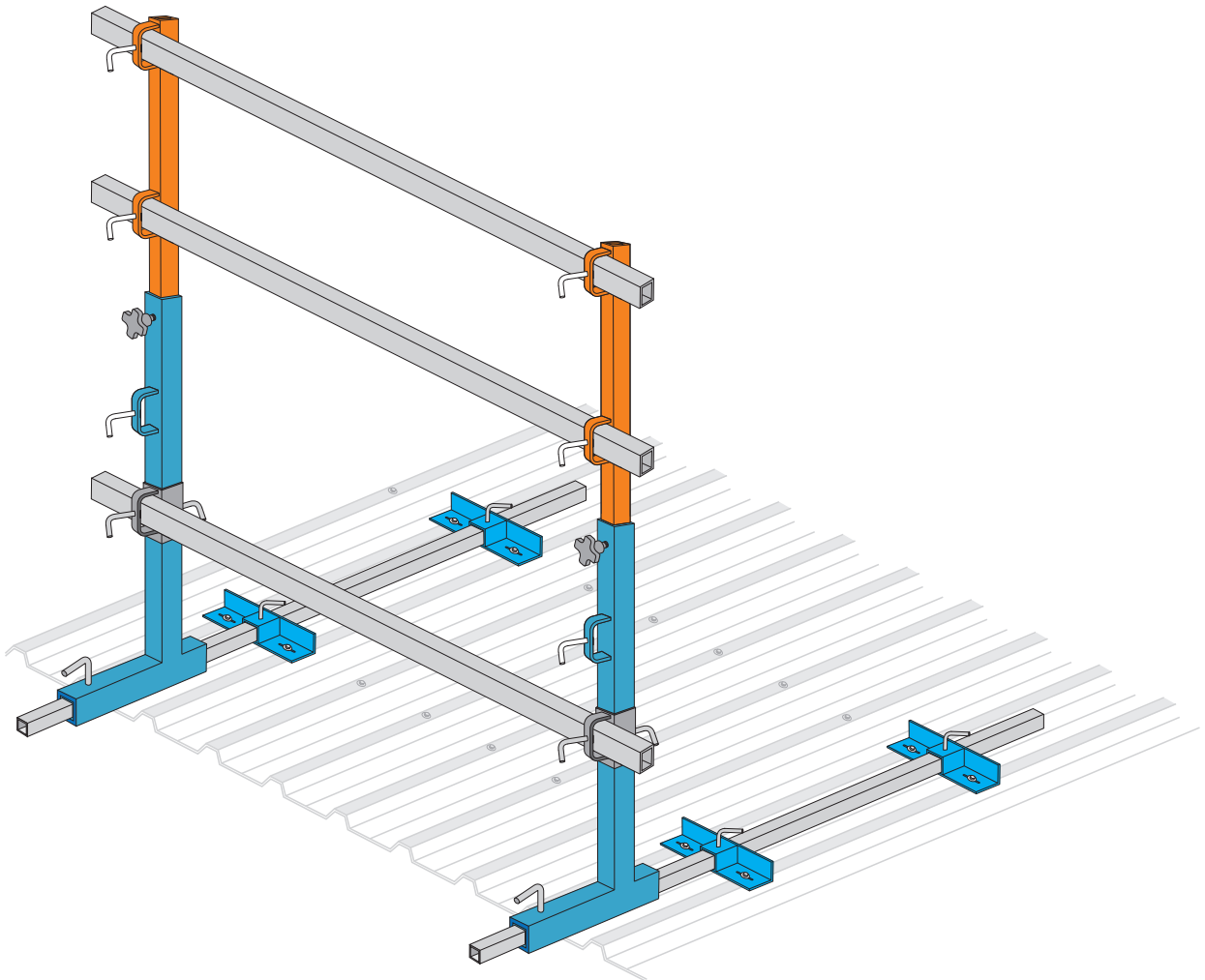

## Roof Mounted Handrail System

Aldeck

Gable End

